

Jandy®

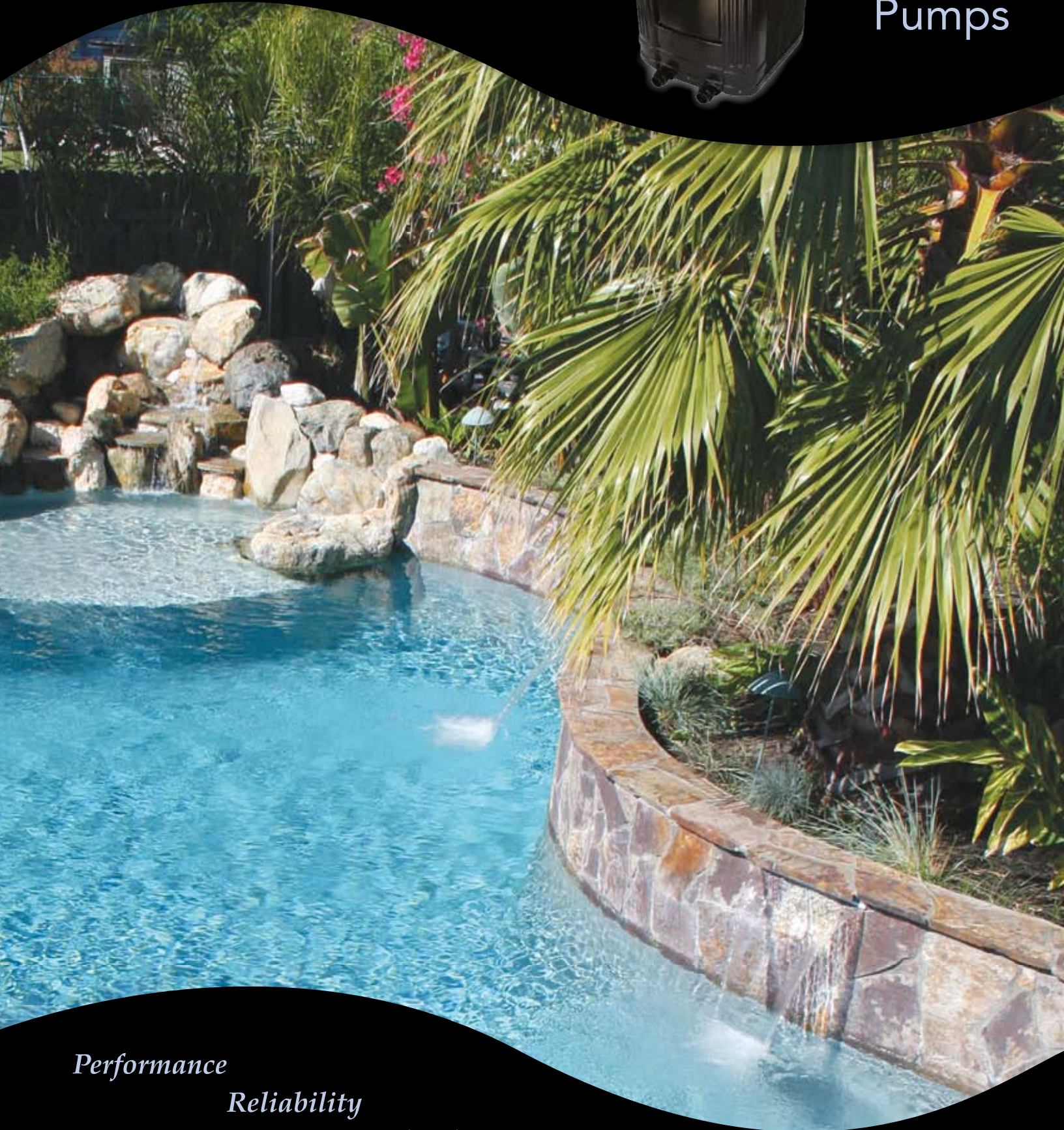

AE2000
Heat
Pumps



Performance

Reliability

Technology



AE2000 Heat Pumps

Jandy Air Energy heat pumps are the most efficient, trouble-free swimming pool heat pumps in the industry. Heat pumps simply take the heat from the air and transfer it to the water — making the heating process clean, efficient, ecologically safe and most of all, cost effective.

AE2000 STANDARD FEATURES



- **Digital Control Panel**
Displays the current pool/spa temperature and monitors the operating status of the unit. Includes lockable control panel cover.
- **Titanium Heat Exchanger**
Lifetime Warranty
Delivers superior hydraulic flow
- **Air Defrost**
Allows the heater to operate at lower air temperatures
- **Patented Auto Heat**
This feature maintains your pool temperature automatically, 24 hours a day, overriding the pool time clock.
- **Extra-Large Evaporator Coil**
Our special lanced-fin design collects more heat as the outside temperature starts to drop
- **Automation Ready**
Allows easy connection to Jandy Controls and other pool/spa automation systems, automatic valve systems, and remotes
- **Commercial Grade Compressor**
Our scroll compressor is the quietest on the market
- **Durable Polymer Cabinet**— Rust and corrosion-free for life

ACCESSORIES

- **Digital Remote Control Panel or Remote Control Kit**
The Remote Panel allows the user to control all heat pump settings, or automates pool-to-spa switching from a remote location. The Remote Control Kit includes two Jandy Valve Actuators and Remote Control Panel.

AE2000 SPECIFICATIONS

BTU/hr* Output	100K
C.O.P.	5.30
Voltage	208V-230V / 1/60
Supply Circuit	40 AMPS
Compressor	Scroll
Heat Exchanger	Titanium**
Flow Rate G.P.M.	30-125 Optimum
Dimensions (in.)	33" Width/ 38" Height/ 41" Depth
Weight (lbs)	275

*Tested and Certified according to the 80-80-80 standard

**Corrosion-Free Technology not affected by chemical imbalances and/or chlorine generators

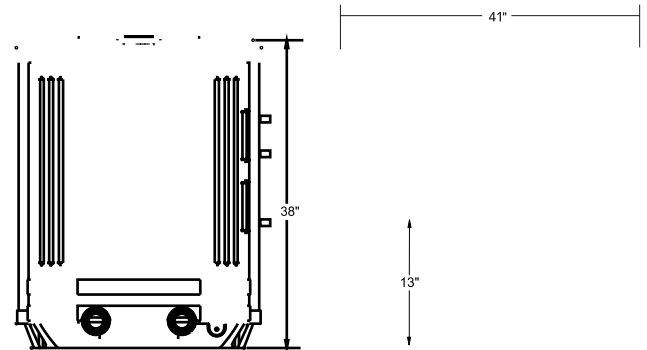

IMPRESSIVE WARRANTY

All Jandy heat pumps are backed by a highly trained technical support department, and by some of the strongest and most inclusive warranties in the industry. See our written warranty for complete details.

